

Quick Reference Guide

Hardware	1
Tips Before Installing	2
Top Tracks	3
Standards	4
Prepare for Lighting	5
Standards & Brackets	8
Back Panels	10
LED Lighting	11
Shelves	13
Drawer Boxes	15
Gliding Frames	19
Mesh Drawers	20
Accessories	21
Finishing	30

Document needed: Custom Design Space Plan (if you worked with a Design Specialist)

Tools needed: pencil, level, power drill, drill bit set, #2 Phillips head bit for power drill, #2 Phillips head screwdriver, hammer, tape measure, ladder or step stool, Elfa 2' spacer, plastic mallet, scissors.

TIP

- Remove all contents from your space and donate or sell all items no longer needed.
- For closets, hang clothes that you are keeping on a garment rack outside the closet during installation.
- Take out any old shelving and/or closet rods. Patch and repaint walls.
- Tape the page(s) of your custom Elfa design to the corresponding wall.
- Refer to your design for placement of your Elfa. Lay out all the products by type, size and wall.

Hardware

Based on what you have told your designer, you have been provided with the correct hardware needed to complete the installation based on your wall construction. Below are instructions for installing each type of hardware:

1 Wood Screw

Used for mounting the Top Track into drywall over wood studs or directly into wood.

Drill a hole with a 1/8" / 3mm drill bit the length of the drill bit.

TIP

- Rake the wood screw over a bar of soap before inserting it into the wall. This will make tightening the screw easier.

2 Drywall & Plaster Anchor

Used for mounting the Top Track into 1/2" / 13mm drywall (most common wall type), or 5/8" / 15mm to 1" / 26mm drywall/plaster.

Enlarge the hole with a 3/8" / 10mm drill bit.

Remove the screw from the white anchor, ensuring the gray insert stays in place.

Tap the anchor into the hole with the plastic mallet.

Discard the grey spacers that are included in the packaging (not shown).

3 Sheet Metal Screw

Used for mounting the Top Track into drywall over sheet metal studs.

Drill a hole with a 1/8" / 3mm drill bit the length of the sheet metal screw.

4 Concrete Screw

For concrete/masonry (cinder block or brick), drill a hole with a 5/32" / 4mm masonry drill bit the length of the concrete screw.

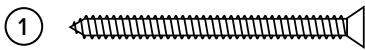

Wood Screw



Drywall & Plaster Anchor



Sheet Metal Screw

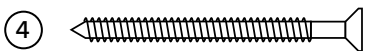

Concrete Screw

Tips Before Installing

Overall Process For Installing Any Décor+ by Elfa Space

- Always start by mounting your Top Track.
- If lighting is part of your solution, run Lighting Cables through your Hanging Standards using the Cable Organizers and pull connector ends through the correct slots (bend ends back so they don't fall back through the slots) according your Space Plan. Allow Lighting Cable to hang out 3"-4" / 75mm-100mm from the bottom of the Standard.
- To square up the solution, first hang Standards on the Top Track. Push Standards together and add all Brackets. Position Standards according to your Space Plan. Add top Shelves to keep Standards in place. Use a level to square up Standards. Use a pencil to mark holes for securing Standards to wall. Remove Shelves used to square up your solution. Slide Standards over so you can drill pilot and anchor holes. Insert anchors. Slide Standards back into place. Do not screw the Standards to the wall at this time.
- Connect Lighting: Secure Transformer in Cable Box. Mount Cable Box to Standards close to your power source. Add necessary Lighting Cables to link Lighting Cables in Standards together, pulling Lighting Cables up and across Top Track as needed. After installing Back Panels (if any) and Wire Shelves, install Light Bars and connect to Lighting Cables. Connect Lighting Cable and bottom of Standard to Transformer. Plug Power Cord into outlet. Install cable covers.
- If Back Panels are part of your solution, secure an outside Standard to the wall (if there is a Standard next to an obstruction, secure THAT Standard). Install Back Panels, securing the next Standard as you go.
- Install Shelves working from the top down.
- Build all Drawer Boxes. Install Drawers working from the bottom up.
- Add Mesh Drawers as you go.
- If no Back Panels, secure Standards to wall.
- Add any accessories and install covers for Top Tracks and Standards.

Top Tracks

Made of exceptionally strong powder-coated steel, the Décor+ by Elfa Top Track and Standards are designed to stand up to heavier storage needs.

Attach Top Track on Wall

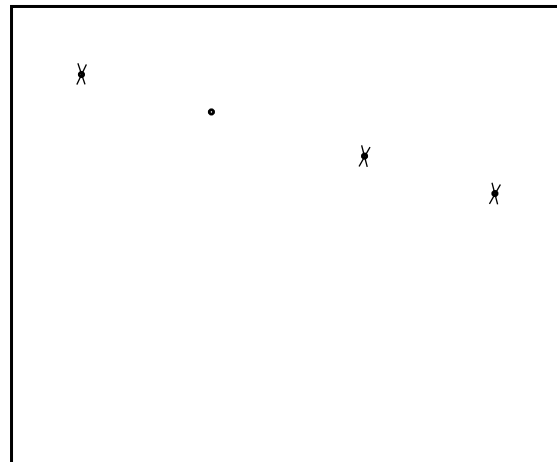
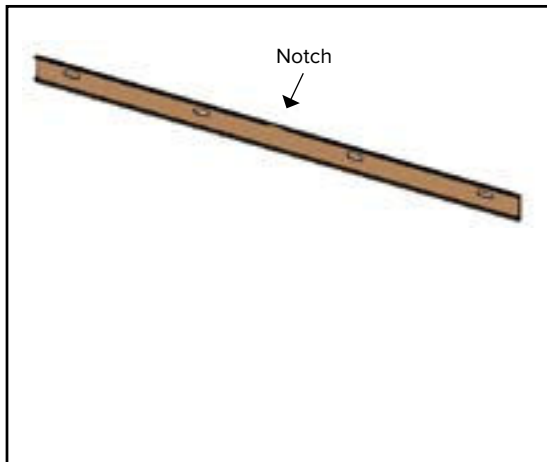

Measure up from the floor approximately 94½" / 2,401mm and mark. Level your Top Track at mark and draw a line across the Top Track. Mark holes.

TIP: Position the Track with the notch at the top and hit at least one stud. Track must be placed at least 1" / 26mm from ceiling to allow clearance to hang Standards.

Pull Track and drill pilot holes with a 1/8" / 3mm bit. Oval-shaped holes make it easier to hit a stud. Enlarge holes with no stud with a 3/8" / 10mm bit. Place drywall anchors.

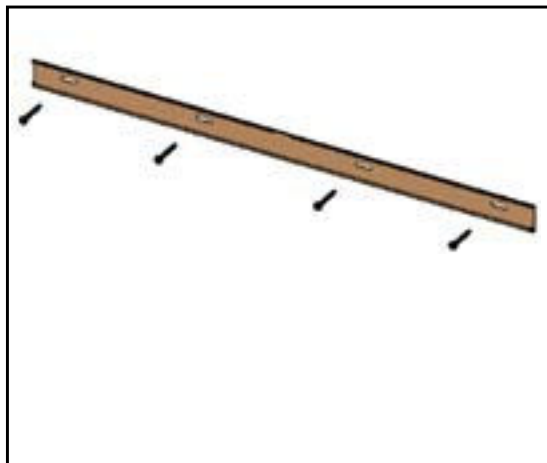

Place the Track on the wall with the notch at the top, insert and tighten all the screws using a power drill with a #2 Phillips head bit. To avoid stripping the screws, finish hand tightening with a #2 Phillips head screwdriver. Attach to at least one stud.

NOTE: Extension Standards and Adapters are only needed for taller solutions. If your solution is a standard height, skip to page 5.

Standards

Attach Extension Standard & Adapter

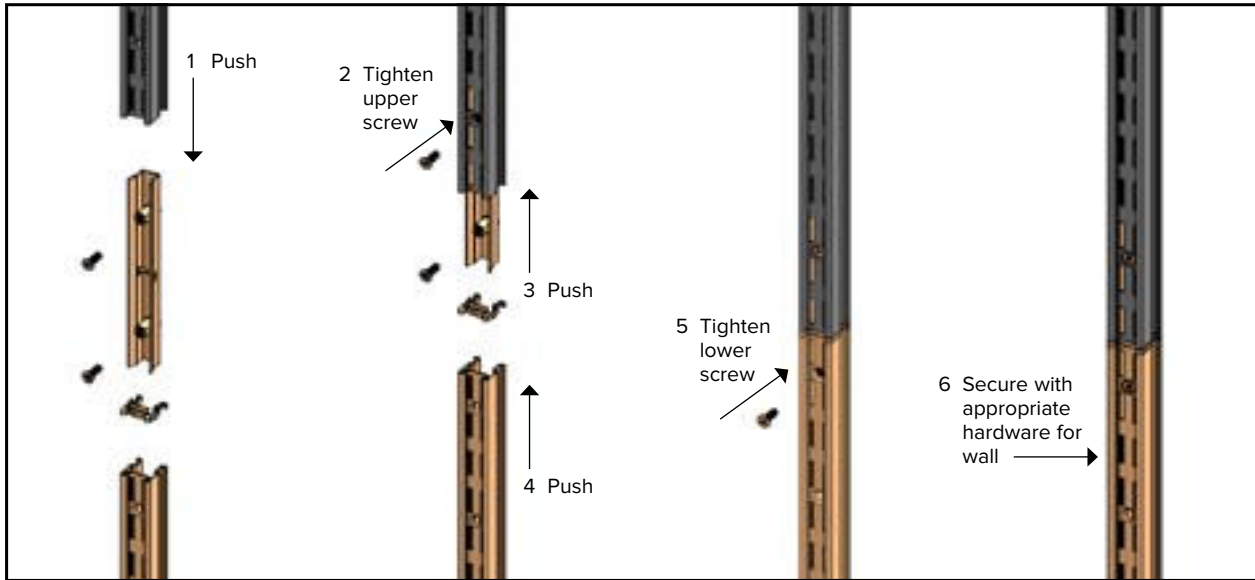

Use the Extension Standard and Adapter to create a longer Standard for taller solutions. Push the Standard and the Extension Standard together over the Adapter. Use the included wrench to secure with the two screws.

NOTE: Brackets can not be installed at the connection of the Extension Standard.

NOTE: If your solution does not include lighting, skip to page 8.

Prepare for Lighting

Please refer to your Custom Design Space's Lighting Plan for which Standards to place cables in.

Run Lighting Cables Through Standards

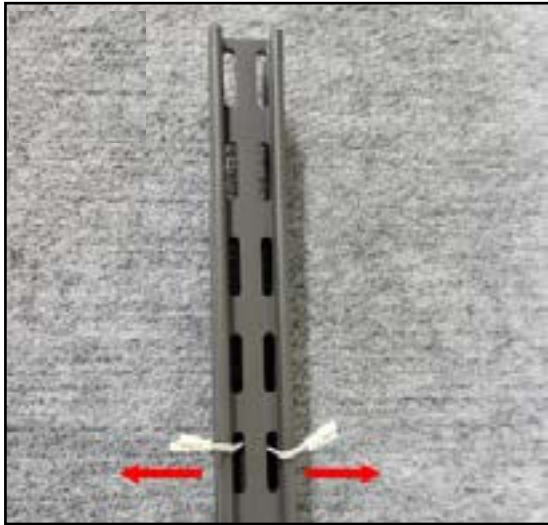

Feed connector ends of Lighting Cable through the correct slots for where your lights will be placed (according to your Space Plan). One split of the Lighting Cable will plug into the wire coming off your light. If you have more than one light, you will use the other end to connect to another Lighting Cable. (Only one end will go through the slot.)

TIP: Fold connector ends back so they don't fall back through the slots.



Turn the Standard over so the back is facing up. Use 3-4 Cable Organizers along cable. The cable should be in the middle slots of the Organizer Clips.

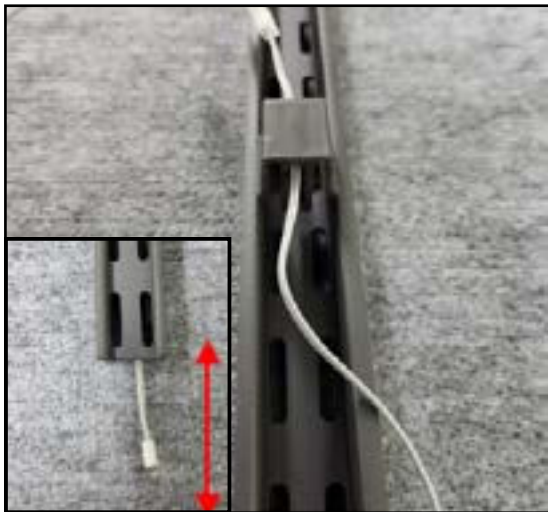

Connect as many Lighting Cables as needed to reach the lower part of the Standard. A minimum of 3"-4" / 75mm-100mm should hang outside the lower part of the Standard.



Push the clips down the back of the Standard so they are flush. NOTE: If using an Extension Standard, Cables can be ran down the back of the Standard in the same way.

Prepare for Lighting

Extension Standards and Hanging Prepared Standards on Track



If using an Extension Standard, Lighting Cables can be run down the back of the Standard in the same way.

NOTE: See page 8 to hang Standards on Top Track.

Prepare for Lighting

Your Installation Box holds your Transformer. Mount it close to your wall outlet or at the bottom of the Standards. Refer to your Space's Lighting Plan.



The Transformer & Power Cord can be mounted loose in the Cable Box or secured with the included double-sided tape.

Connect Wires Together

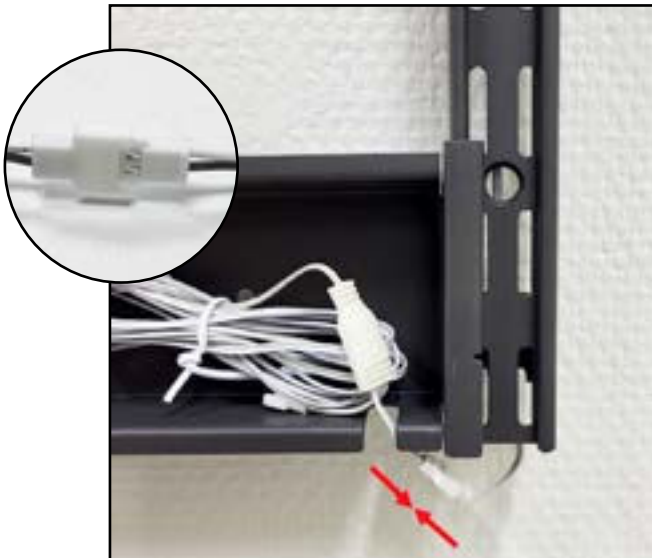

Mount the Cable Box next to the connector end of the Lighting Cable hanging out of the bottom of the Standard. Connect the connectors to each other.

NOTE: Do not plug the power cord into an electrical outlet at this time.

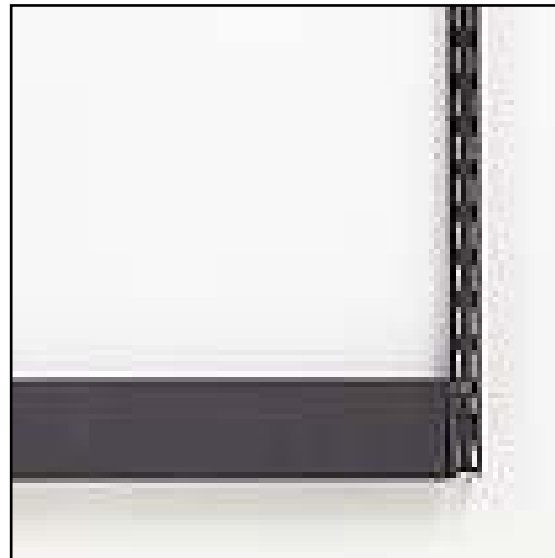

Install Cable Box Cover.

Standards & Brackets

Attach Hanging Standards, Brackets & Square Up Space

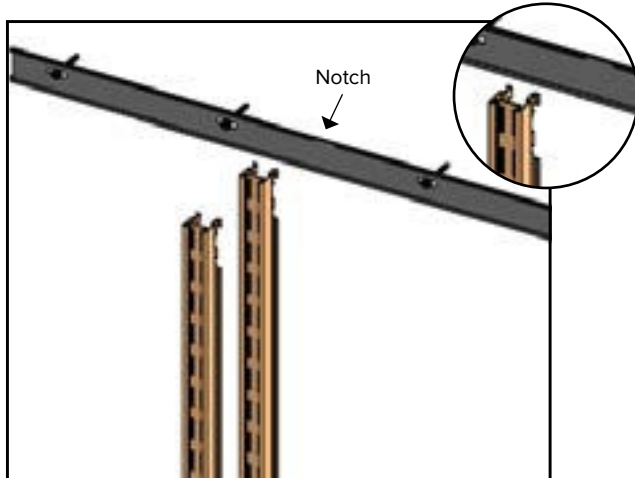

Insert each Standard at the notch in the Top Track. Slide over. Group Standards together to make it easier to add Brackets in the correct holes. Refer to your Custom Design Space Plan for slot placement.

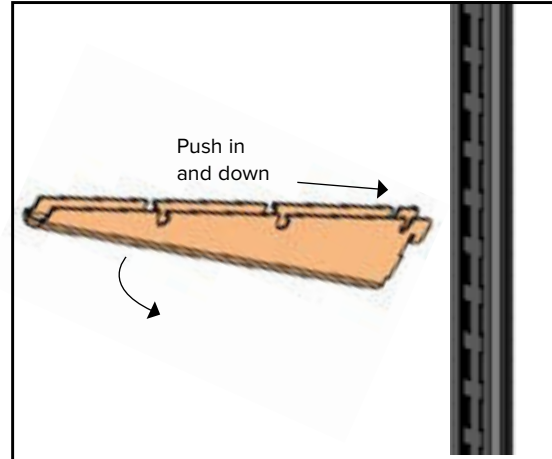

Insert Brackets into correct slots at an angle. Tilt down to secure.

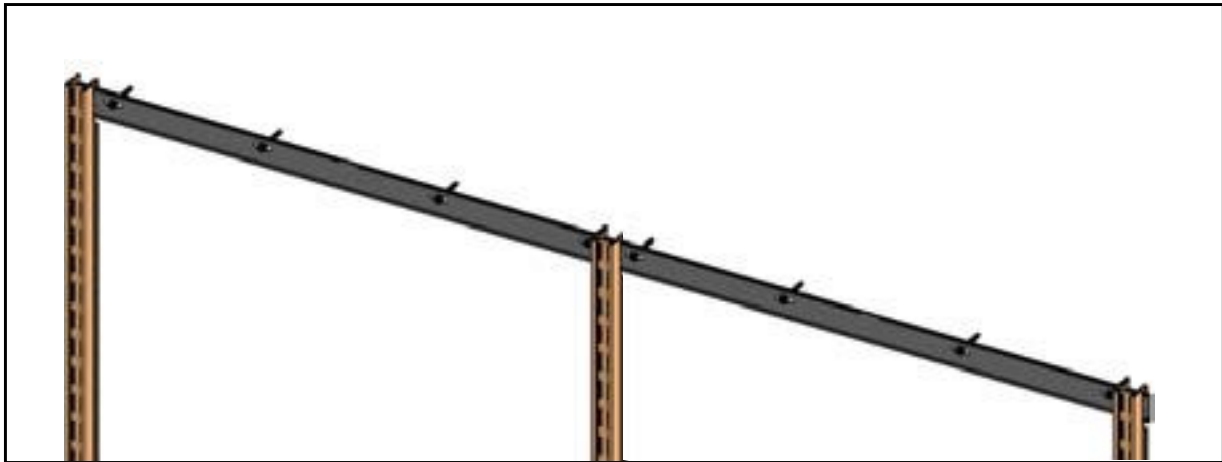

Then use the Elfa Spacer provided to slide Standards to position according to your design. Hanging Standards should be a minimum of 1/2" / 13mm from the ends of the Top Track.

NOTE: Outside of the US, hang standards have a safety stop on each end. There is no need to leave extra space on the ends of the track.

Standards & Brackets

Attach Top Row of Wire or Décor+ Shelves (see page 7) and Square Up Space

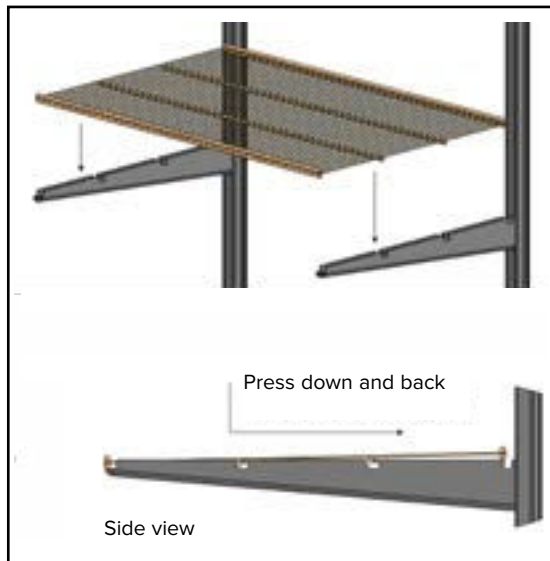

Position Wire Shelf over Brackets with notches aligned. Press down and back to lock into place. Two Shelves can share a Bracket. Complete the top row of Shelving. Use a level to square up the Standards on the wall.

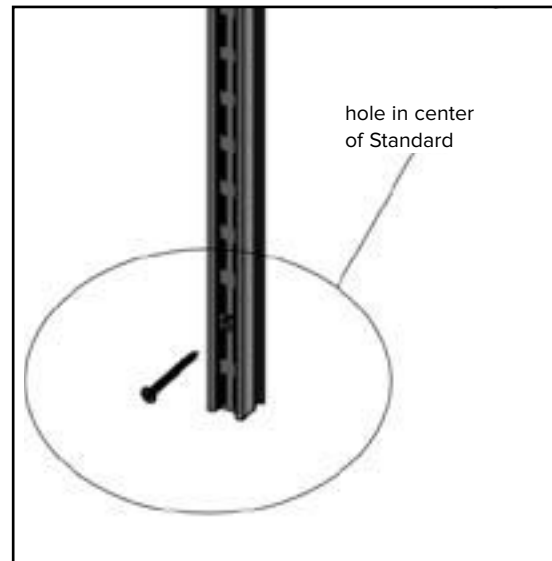

Mark the locations of the middle and bottom holes in the Standards.

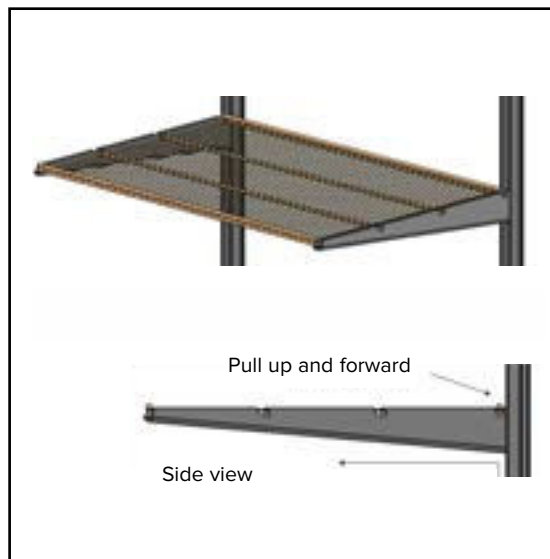

Remove Shelves and set aside. To remove a Wire Shelf, pull up and forward on the back of the Shelf. Slide Standards over a few inches to allow room to drill holes.



Drill a 1/8" / 3mm hole at each marked location. If you don't hit a stud, enlarge that hole with the appropriate drill bit size for the hardware needed for your wall construction. Place anchors in each enlarged hole.

NOTE: Don't secure Standards to wall until installing Shelving and Drawers.

Back Panels

NOTE: Secure one outside Standard to wall. If there is a corner or obstruction – secure THAT standard.

Installing the Back Panels



Hook Back Panel supports into standards to ensure proper spacing and give back panels a place to rest.

TIP: Two-person job.



Slide Back Panel into grooves in standards until it rests on the Back Panel Support.

Adjust Standard as needed to insert Back Panel.

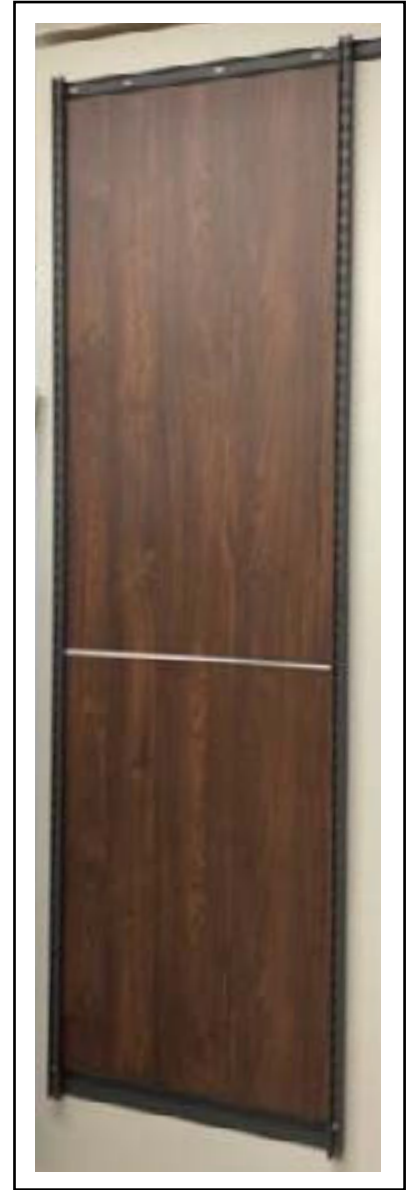

Place plastic Divider on top of lower Back Panel with taller side facing the wall.

Slide upper Back Panel into place along grooves in Standards until it rests on the Divider.

Adjust Standard in for a tight fit.

Anchor Standard to wall.

Repeat until all Back Panels are installed and Standards are anchored.

LED Lighting

Mounting LED Fixtures under a Wire Shelf



Install Light Clips on inside of Brackets.



Position light, pushing one side in place. Lift other side up until straight. Magnet and tension rod will hold in place.

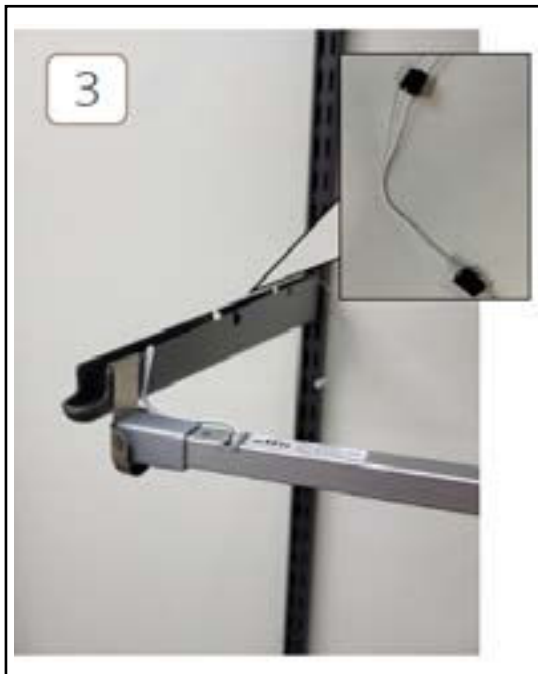

Connect light wire to Link Cable.

LED Lighting

Connection of LED Fixtures across a Top Track

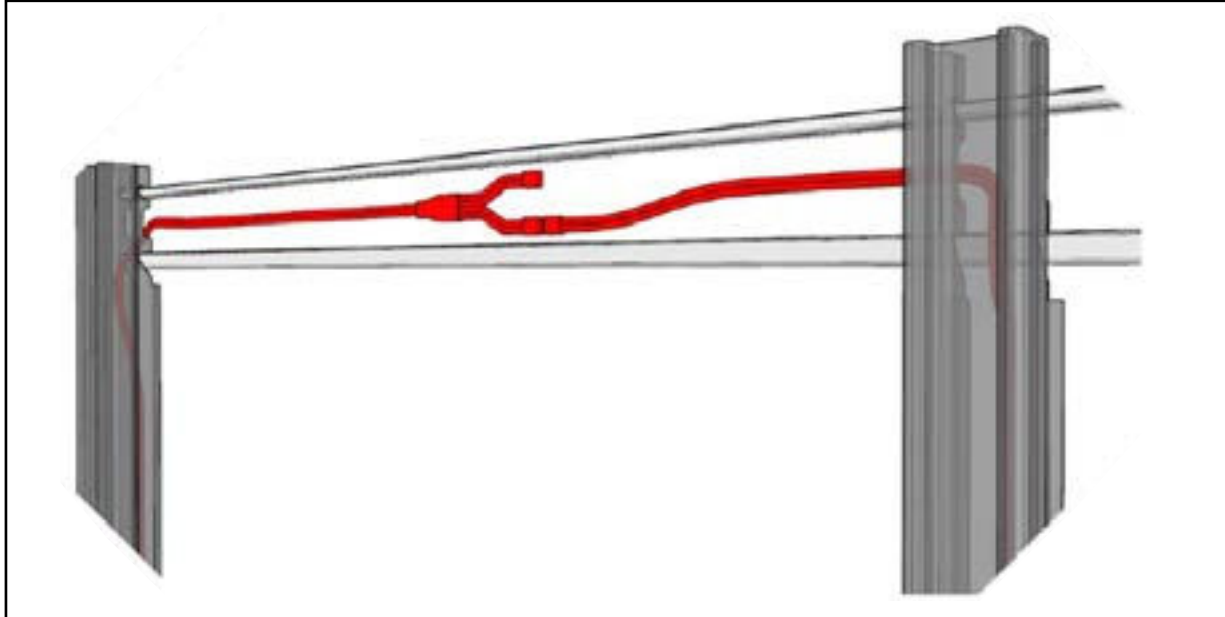

Multiple Lighting Fixtures can be connected even if Shelves are not mounted next to each other. Connect Lighting Cables together and run across Top Track, connecting to Lighting Cable in appropriate Standard.

Pairing Remote

Remote can be adhered to a metal surface with magnets on the back or use included screws to mount to a wall.

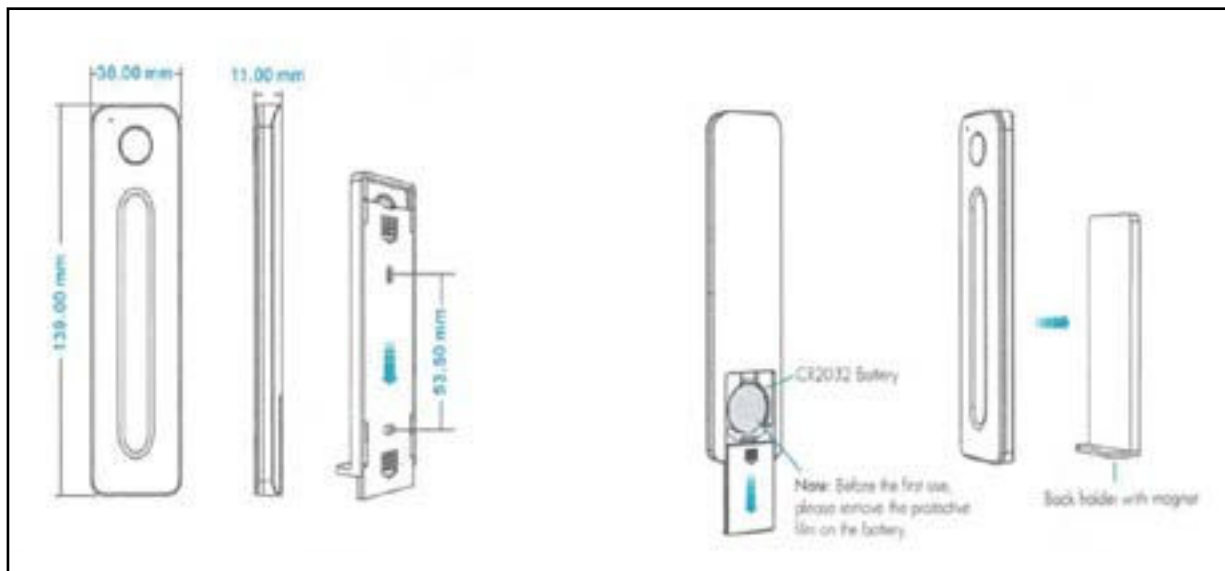

Pairing instructions are included in the remote packaging.

Shelves

Attach Wire Shelf

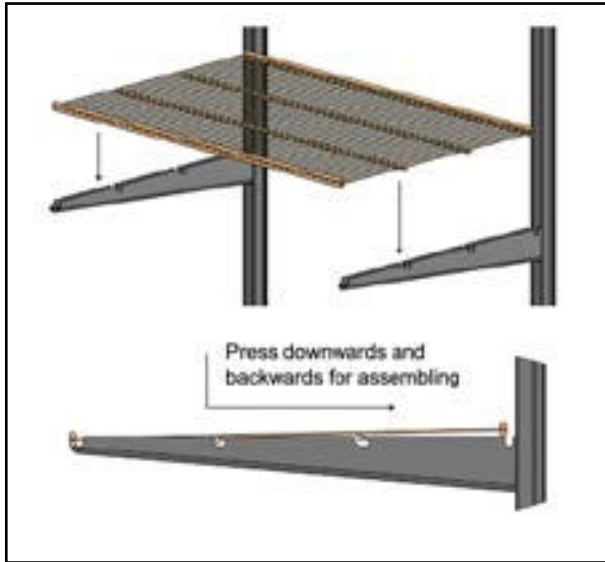

Position Shelf over Brackets with tabs over notches in Brackets.

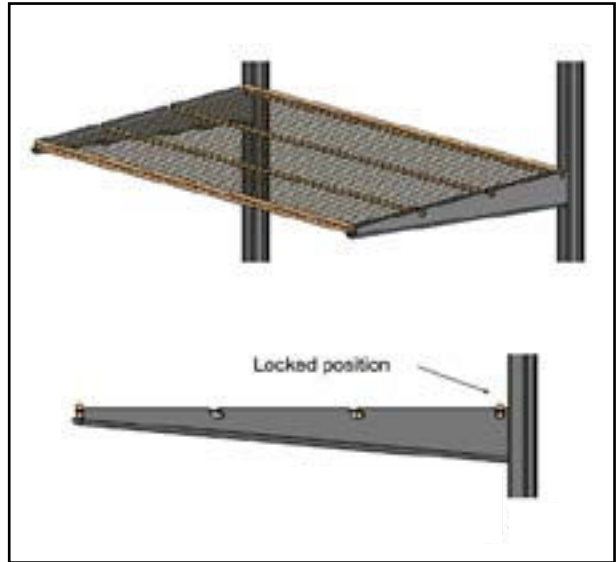

Firmly push down and back to lock in place.

Attach Angled Shelf

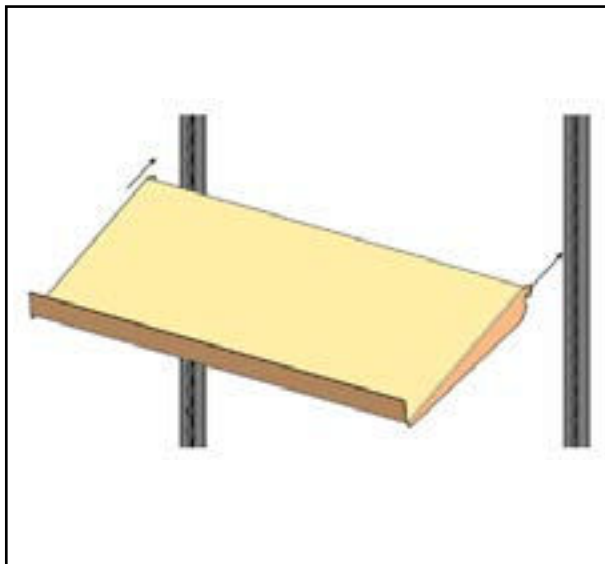

Position Angled Shelf over Brackets with tabs over notches in Brackets.

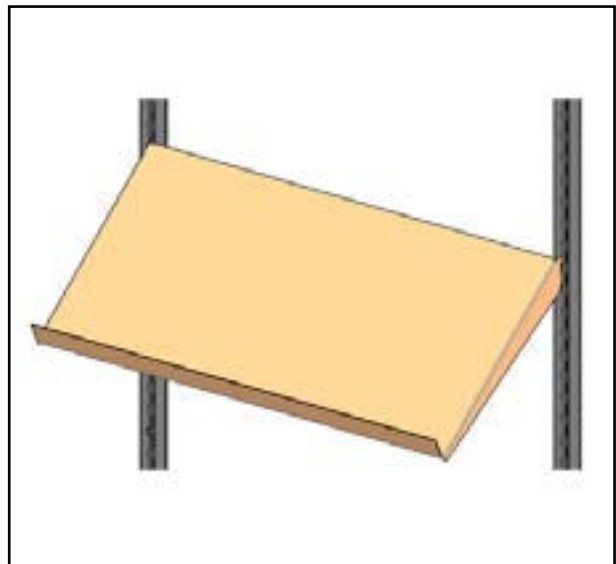

Firmly push down and back to lock in place.

Shelves

Attach Décor+ Shelf

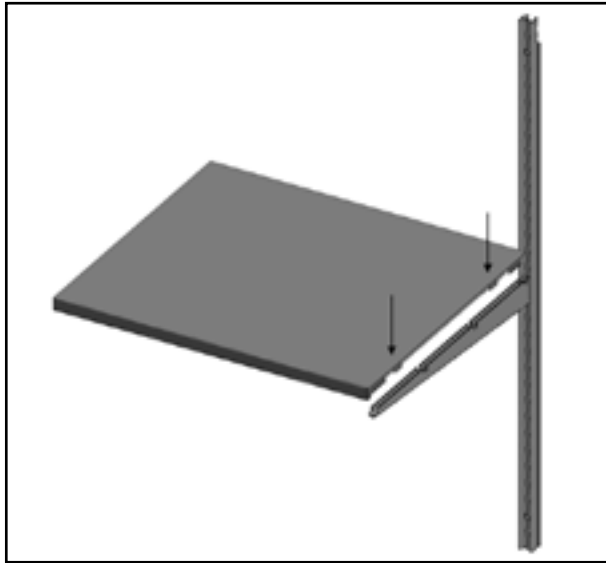

Position Décor+ Shelf over Brackets with tabs over notches in Brackets.

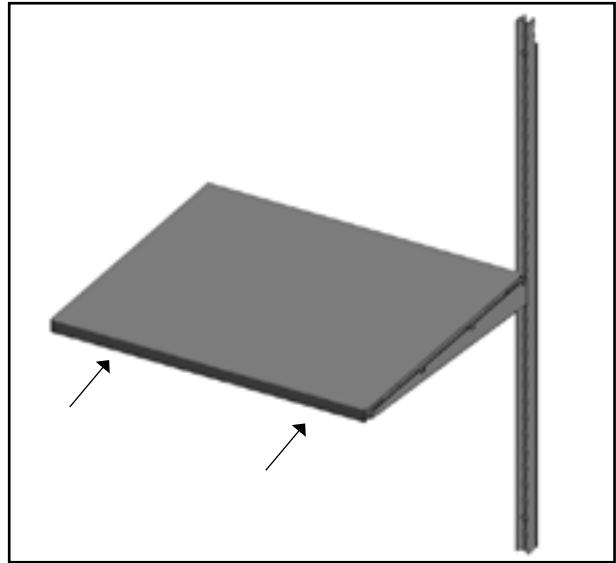

Firmly push down and back to lock in place.

Drawer Boxes

Drawer Box Assembly

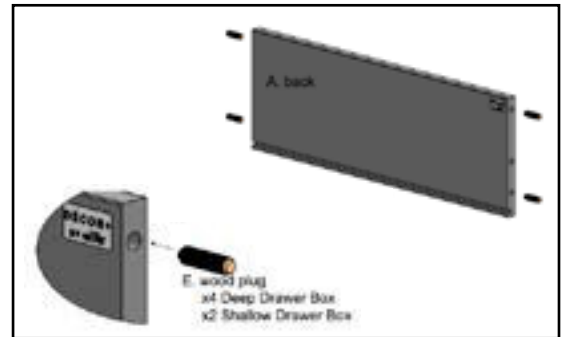
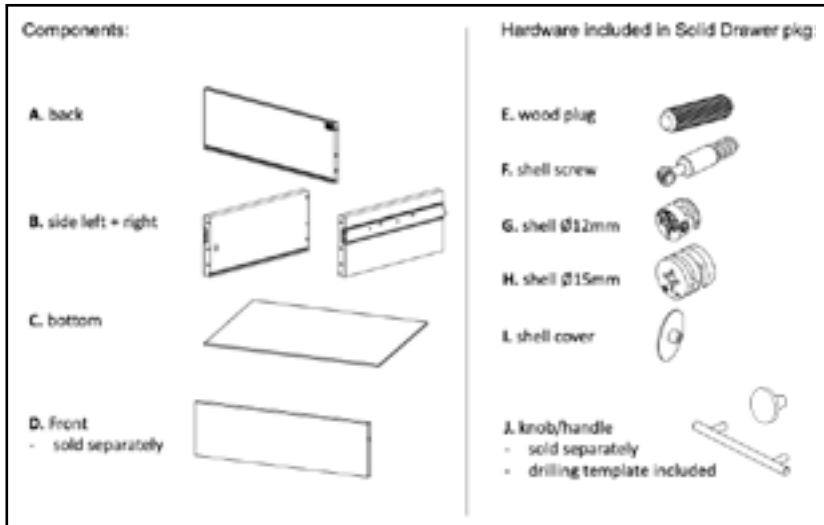

Lay out the three sides of drawer with grooves facing up.

Insert the dowels in two outside holes.

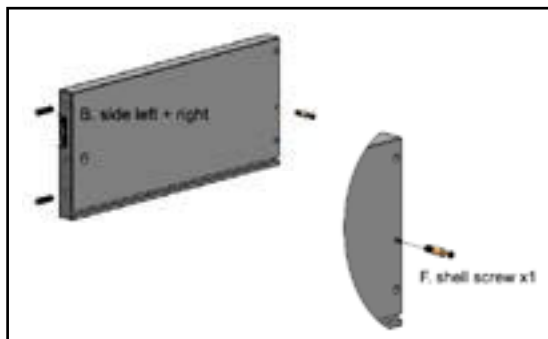

Insert the screw side of the metal post of the camlock into the center hole in each side of drawer using a screwdriver.

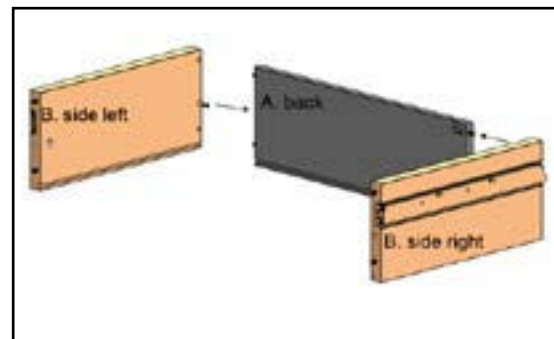

Attach sides to back panel pushing dowels into place firmly.

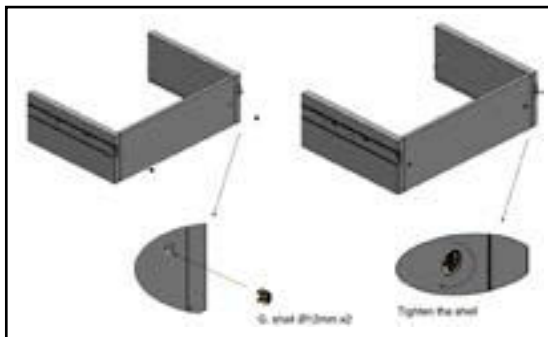

Insert the larger size round camlock into the two side panels. Use a screwdriver to lock the camlock. Hand tighten until it stops.

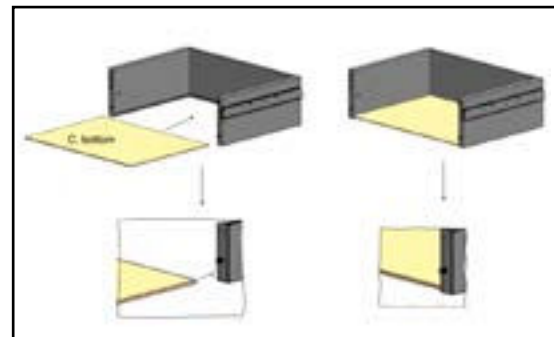

Slide the bottom panel into channel in base of drawer.

Drawer Boxes

Attach Drawer Front

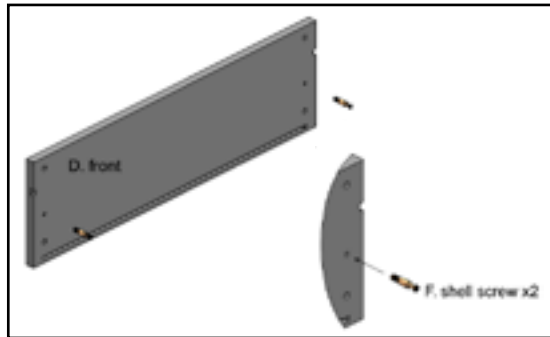

Insert dowels into the front facing of drawer.
Use a screwdriver to insert metal post into center hole. Push firmly in place.

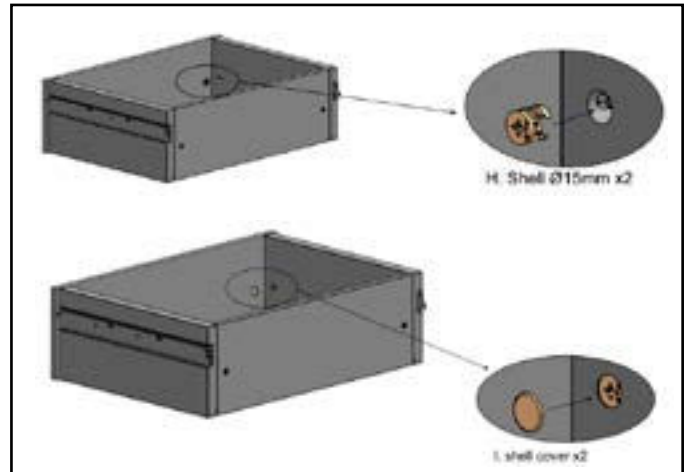

Tighten camlocks with screwdriver.
Snap covers over camlock holes in interior of drawer.

Attach Handles or Knobs to Drawer Front

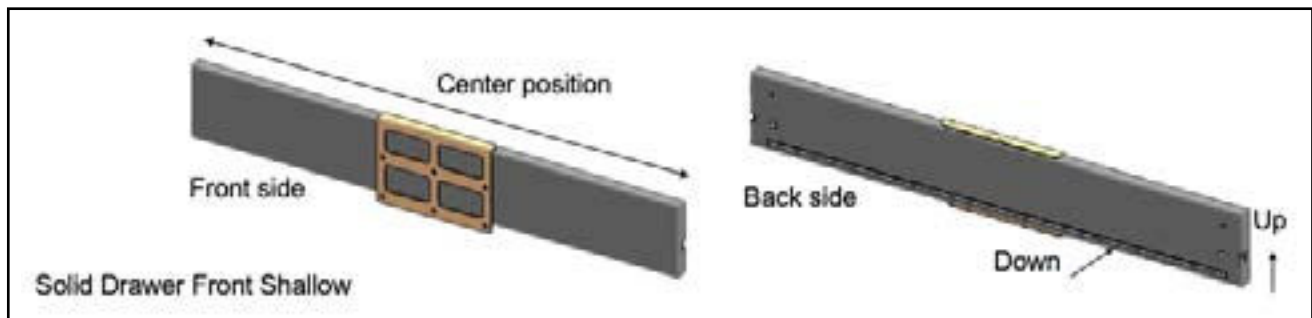
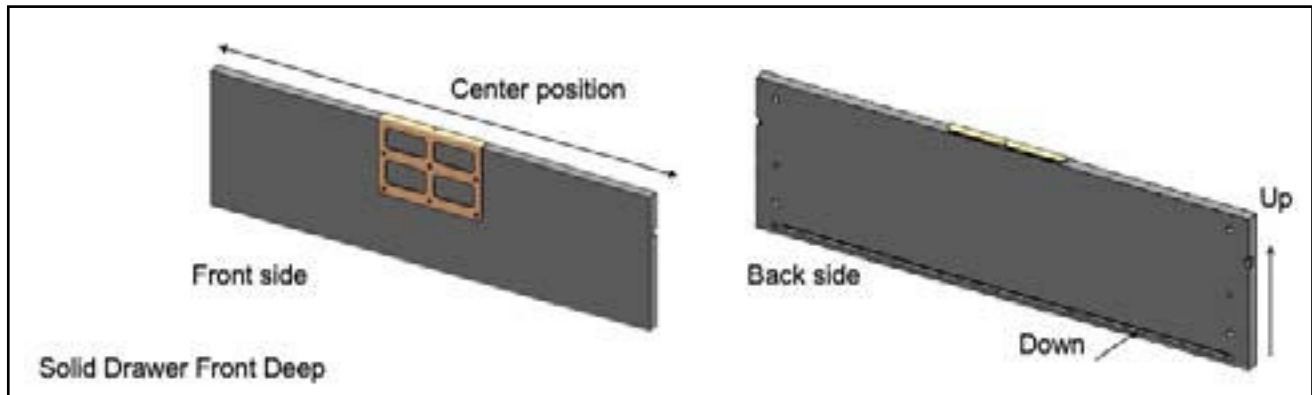

Use Drilling Template to mark position of holes desired.
NOTE: Always drill from the front of the drawer. Use 5mm or 3/16" drill bit.

Drawer Boxes

Attach Handles or Knobs to Drawer Front

Use metal Drilling Template to mark position of holes desired for Handles or Knobs selected. Use a ruler to find the center of the Drawer Front.

NOTE: Always drill from the front of the drawer. Use 5mm or 3/16" drill bit.

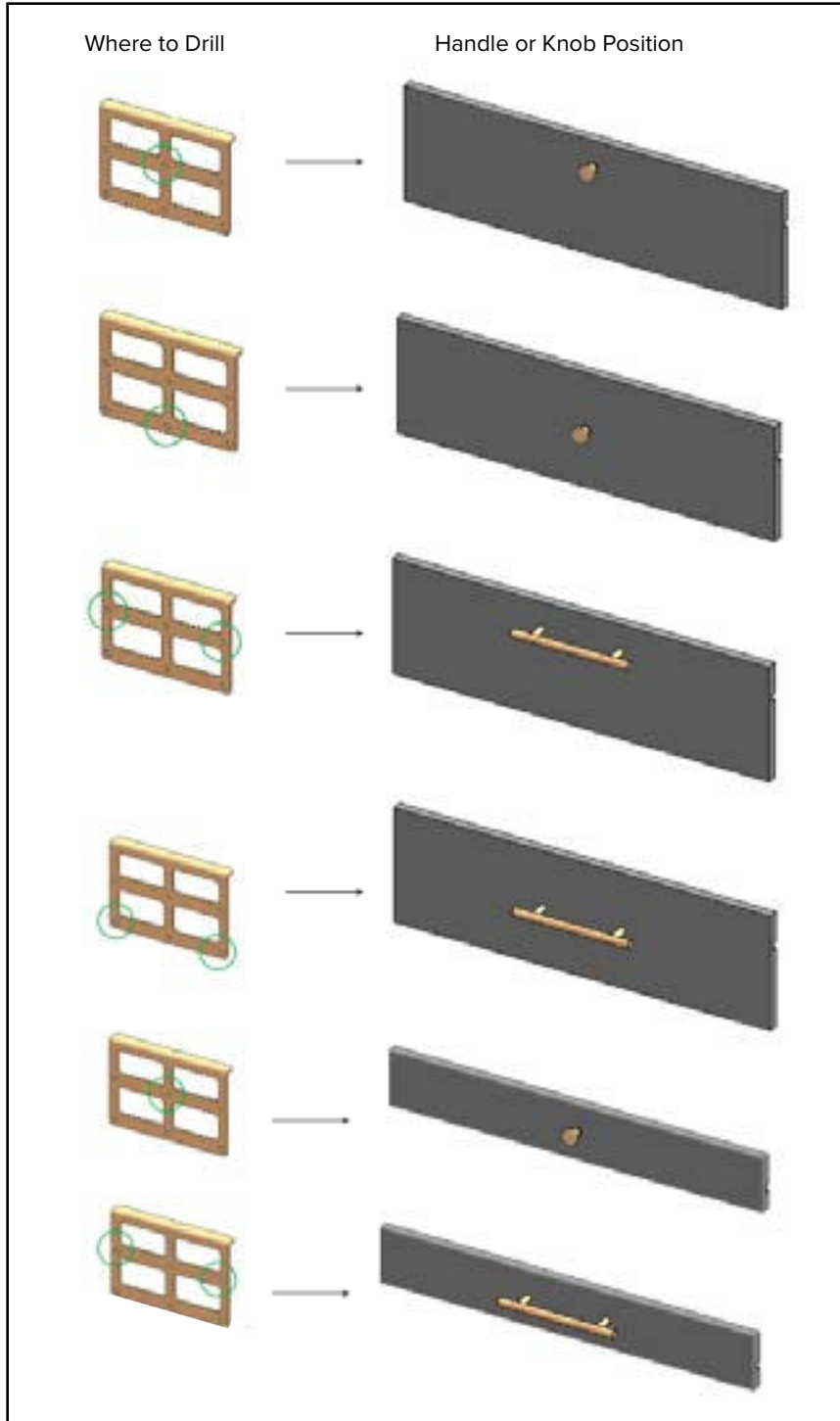

Drawer Boxes

NOTE: Install the lower Drawer Boxes first and work your way up.

Attach Drawer Box to Bracket

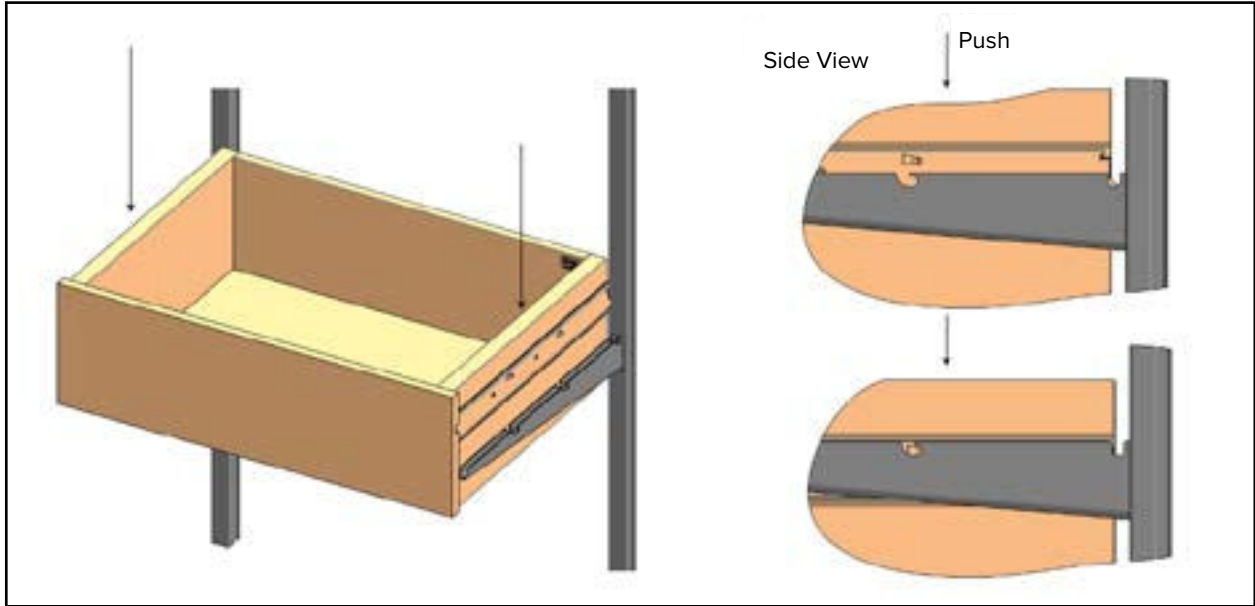

Line up metal tabs of Drawer Glide on Drawer with notches in Brackets.

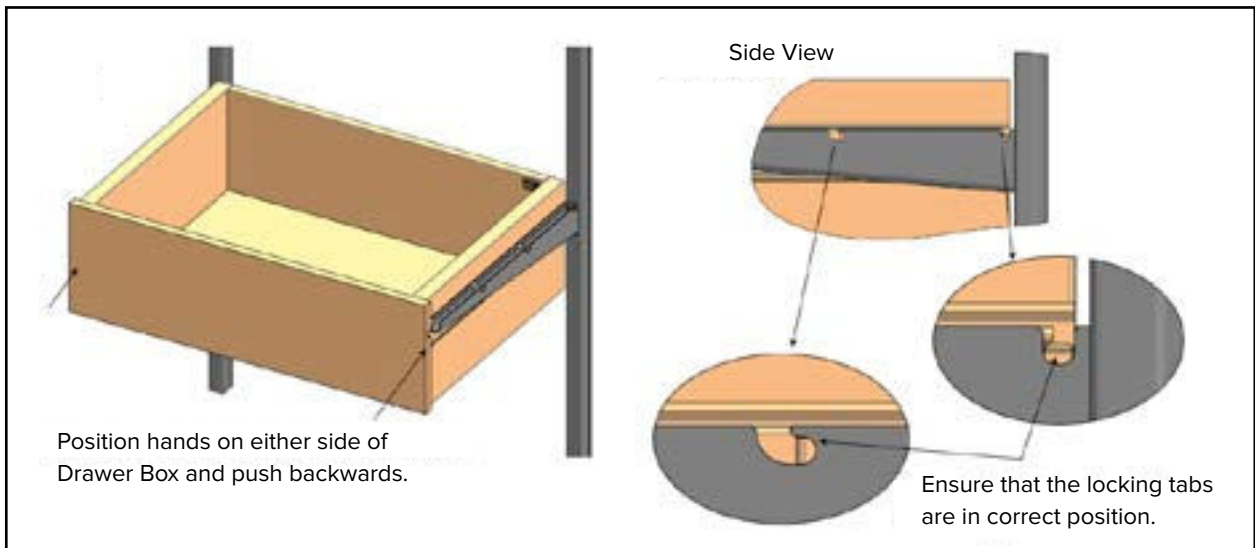

Position hands on either side of
Drawer Box and push backwards.

Ensure that the locking tabs
are in correct position.

Position hands in on either corner of Drawer Front (aligned with the sides of the drawer, fingers to the top of the drawer).

Sharply tap Drawer, pushing it back toward wall to lock Drawer in place.

Gliding Frames

NOTES: Install Drawer Glides from bottom of solution up. Add Mesh Drawers as you go. Gliding Frames are used with Shoe Racks, Shoe Shelves, Pant Racks, and Mesh Drawers. Look for Trim installation hardware in Gliding Frame box.

Install Gliding Frames

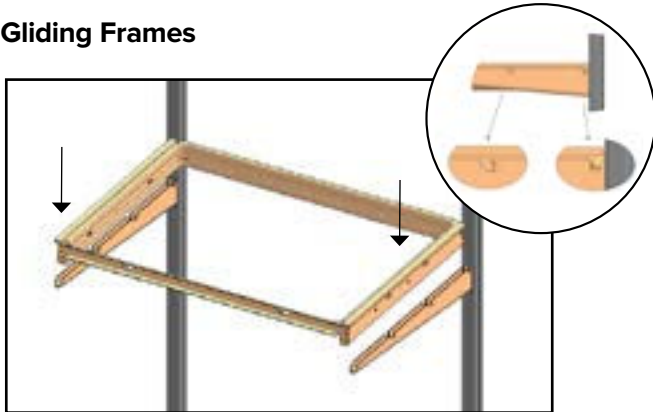

Position Gliding Frame over the Brackets with tabs over notches. Ensure that the locking tabs are in the correct position. (See closeup illustration.) Push down firmly until you hear a click.



Position your hand(s) at the back of the Glider and push sharply to the wall to lock in place.

Push back until you hear a second click.

Attach Slide Trim



Position side Trim pieces with the angled edge to the front, sliding the back under the tab in back of glider.



Attach Glider Trim

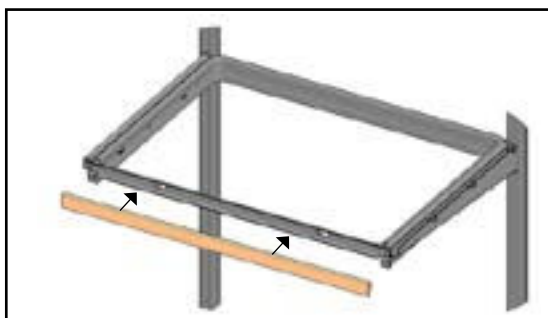

Position front Trim with half moon on bottom.

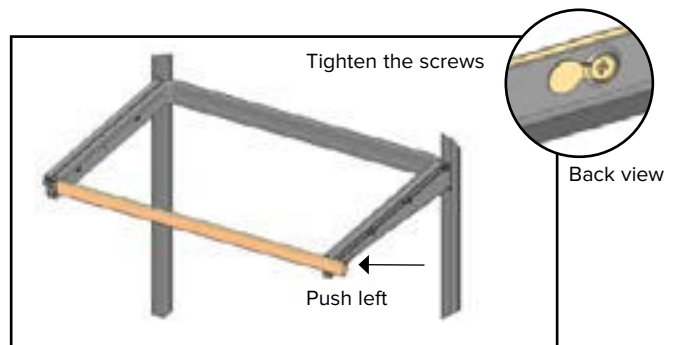

Screw on front piece of trim.

Mesh Drawers

Insert Mesh Drawers

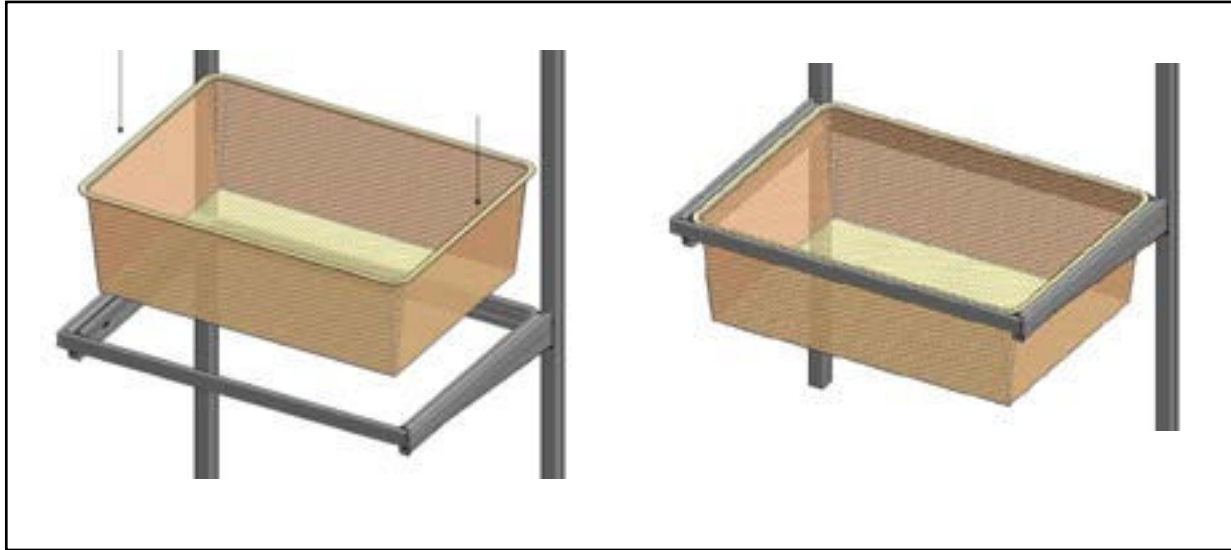

Position Mesh Drawer above Gliding Frame and drop into place. Drop in the drawers as you go, installing from the bottom up.

Insert Mesh Drawer Dividers (if applicable)

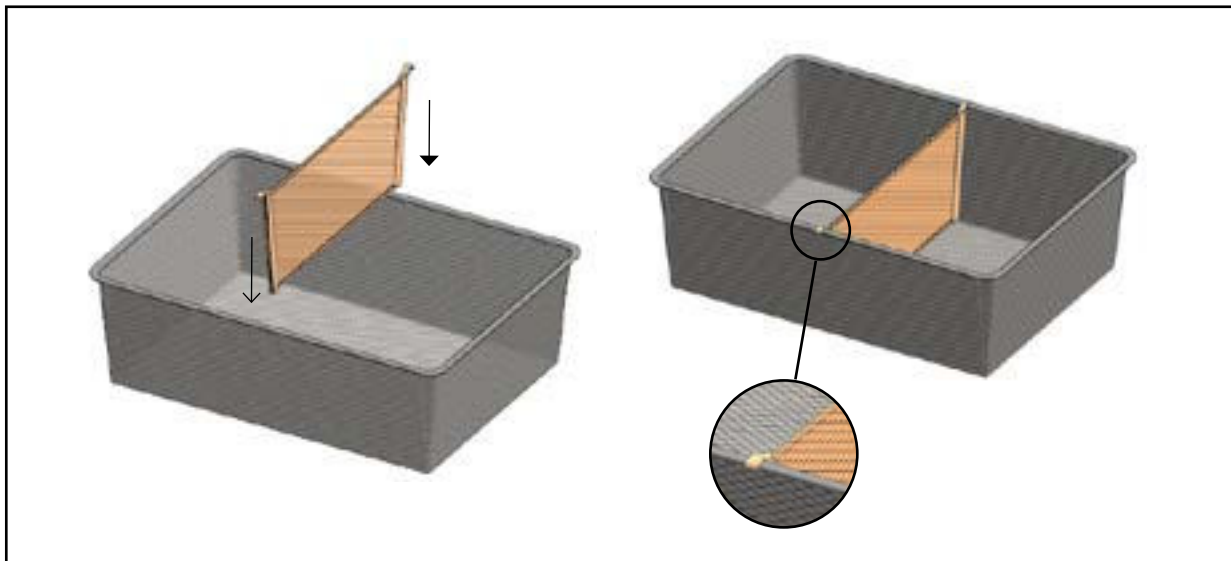

Position Mesh Drawer Divider above Drawer and drop into place.

Accessories

Gliding Shoe Rack

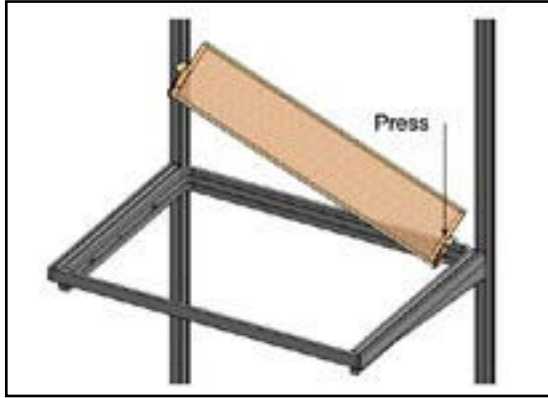

Position Shoe Rack at an angle with clip to the bottom of rack, resting on the clips on inner edge of the Glider frame. Press down.

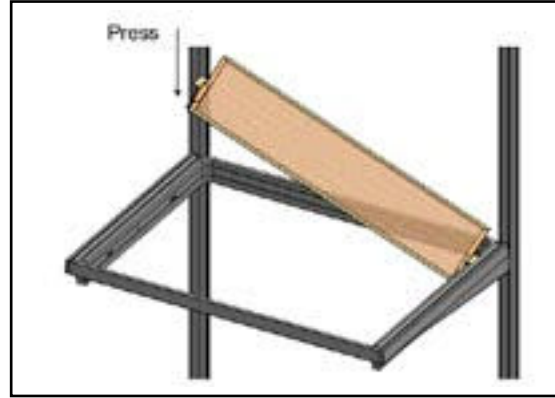

Repeat on other side.



Pull one side forward until Rack is straight.



Repeat with other two Racks.

TIP: Racks can be spaced to accommodate larger sized shoes.

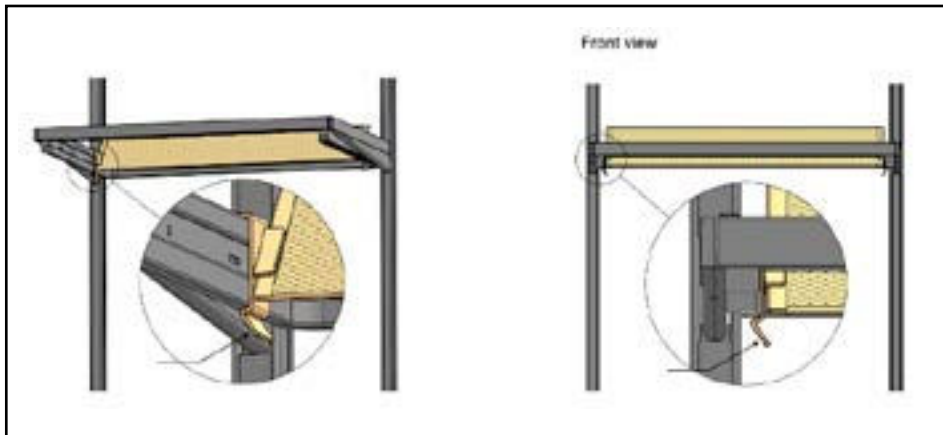

Press the locking tab and push up for disassembling.

Accessories

Gliding Shoe Shelf



Drop Shoe Rack in place, starting with the back side.



Gliding Pant Rack



Position Rod, clipping the back hook over the back part of the Glider.



Press front into place.



Position all Rods into the Gliding Frame. Rods can be adjusted by sliding sideways.



Push the locking tab up to remove a Rod.

Accessories

Closet Rod

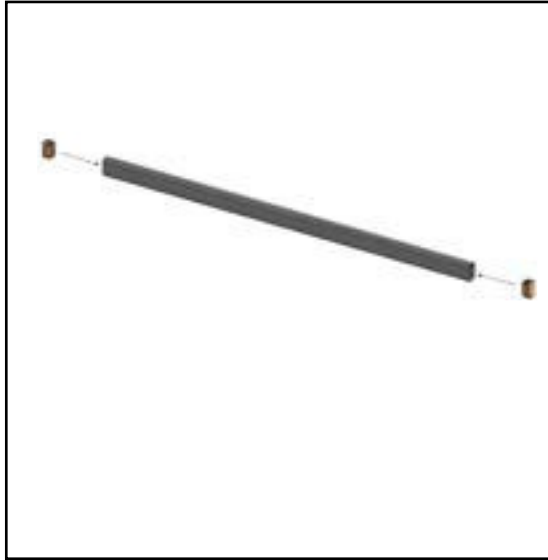

Attach End Caps to Closet Rod.

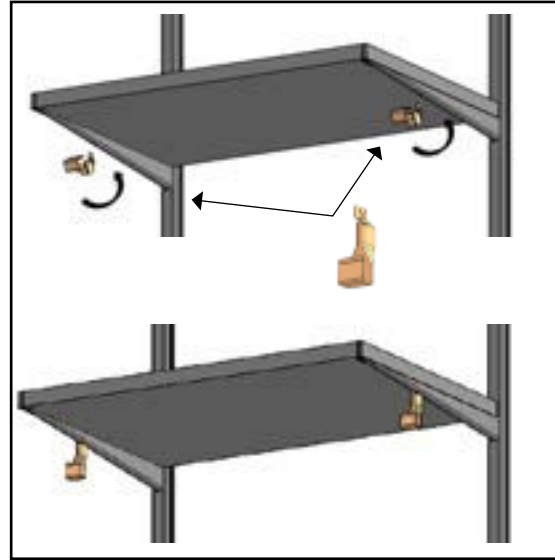

Hang Closet Rod Holders from Shelf Brackets.

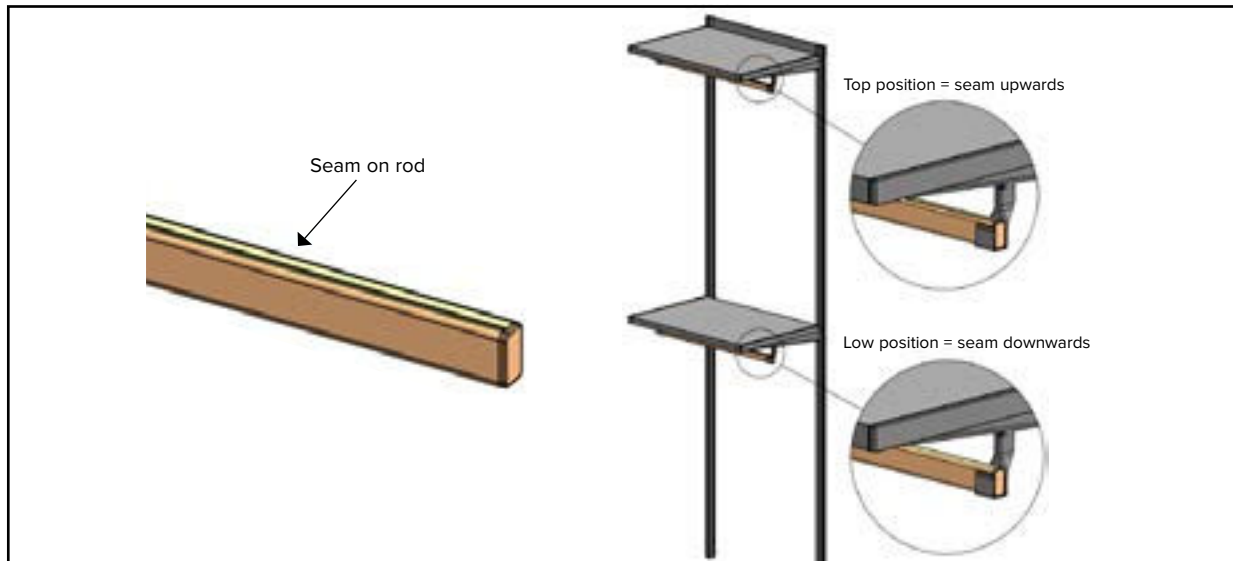

Press Closet Rod into Closet Rod Holders.

Accessories

Trim for Wire Shelves

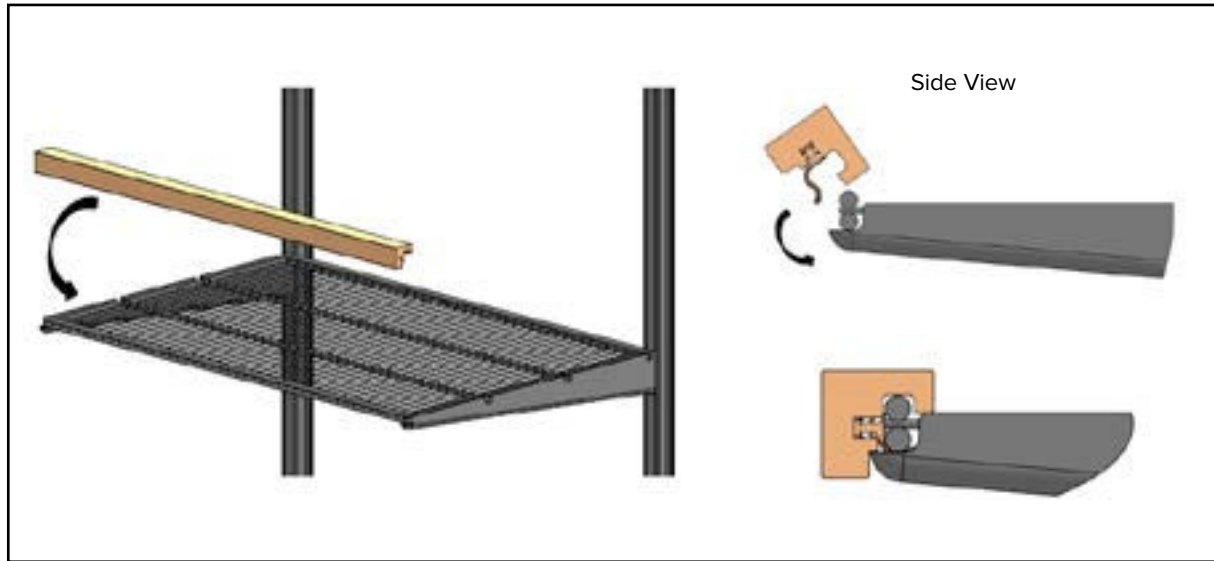

Position trim with plastic clip in front of Wire Shelf.

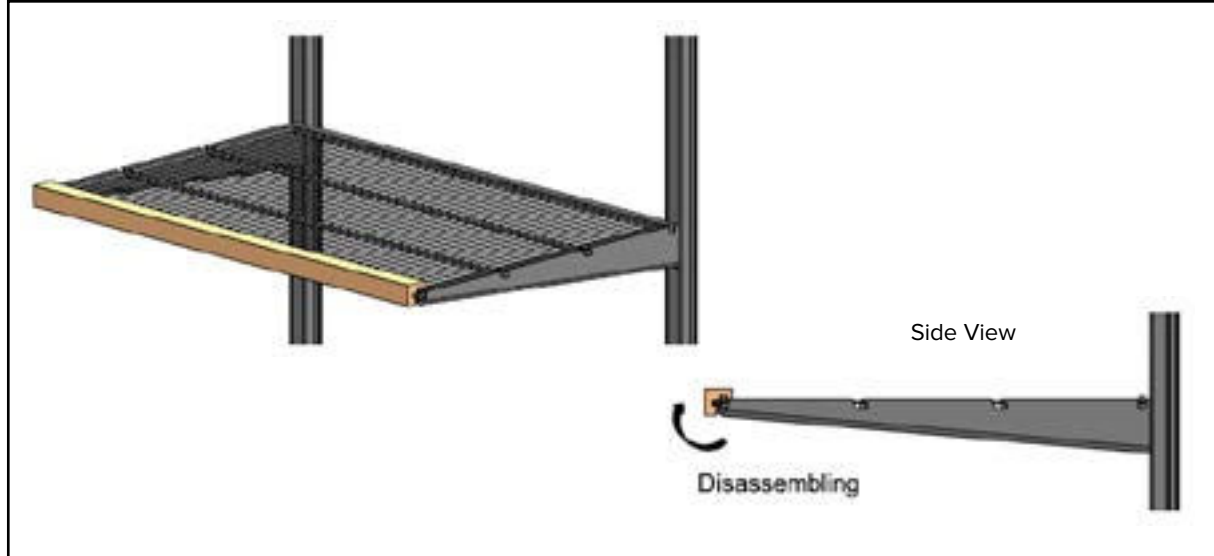

Accessories

Bracket Hook

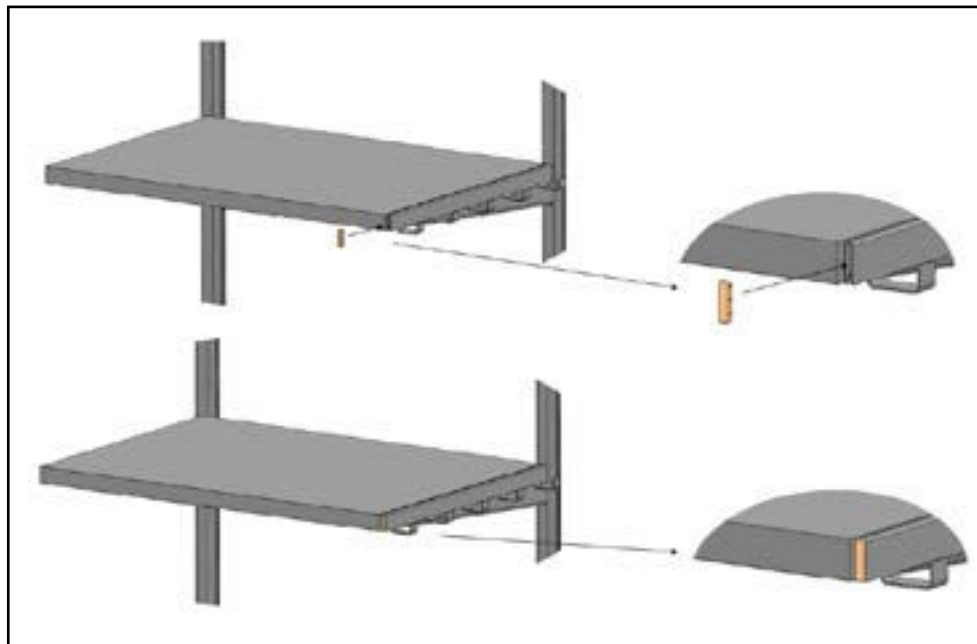
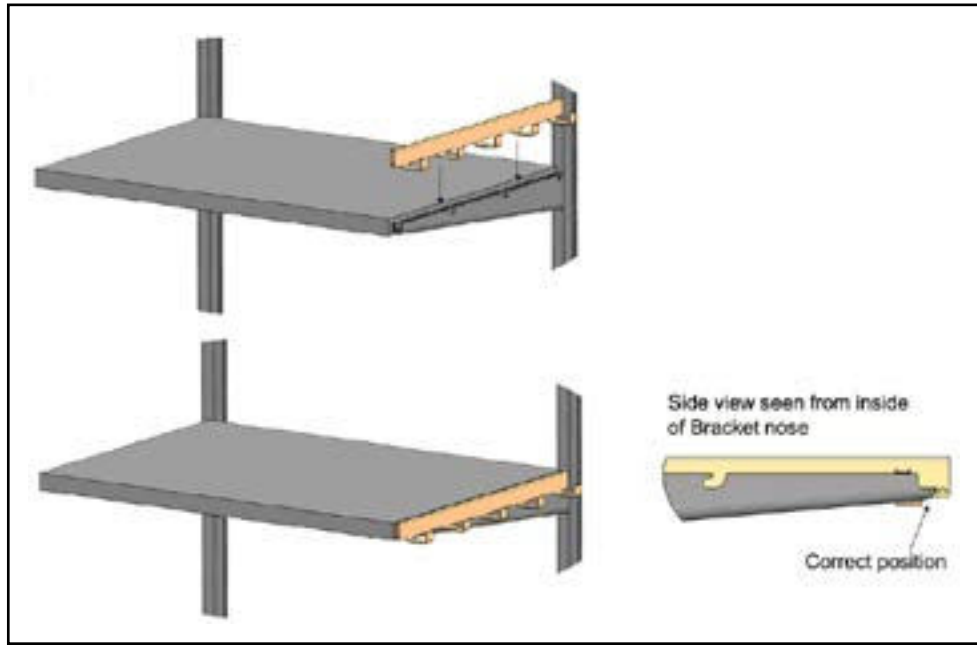

Accessories

Gliding Tie & Belt Rack

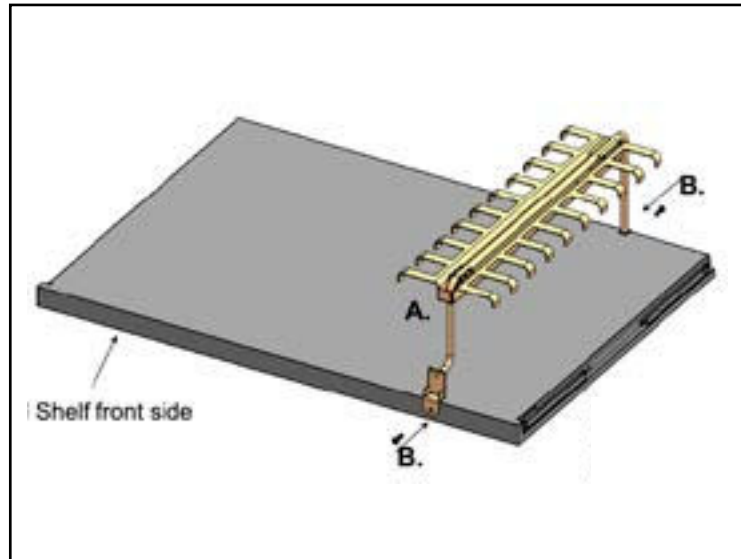
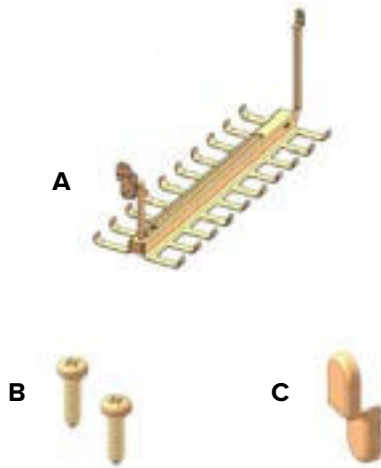

Turn the Décor+ Shelf upside down.

Position A and predrill before inserting Screws B.

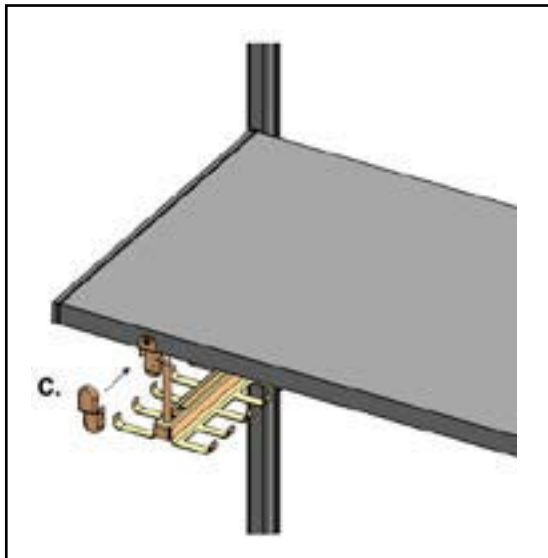

Turn the Shelf back over and reinstall on Standards.

Locate Part C.

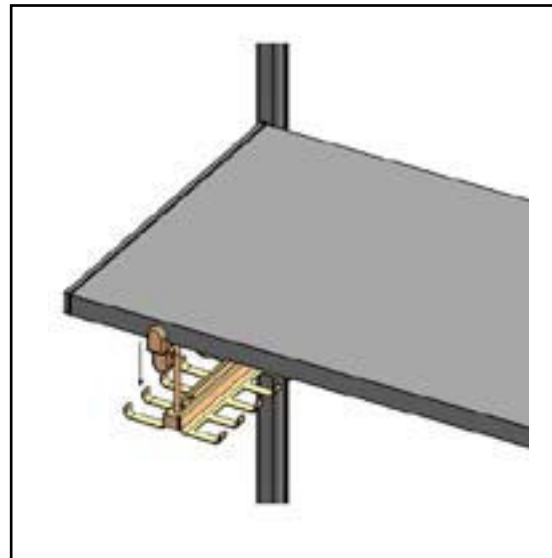

Press Cover C downwards to secure it correctly.

Accessories

Mirror

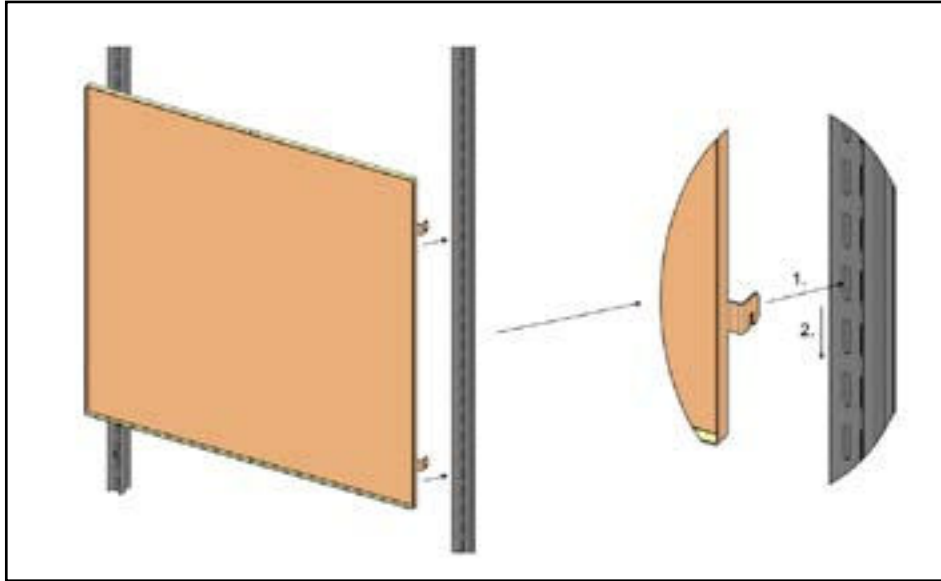

Line up tabs with inner slots.

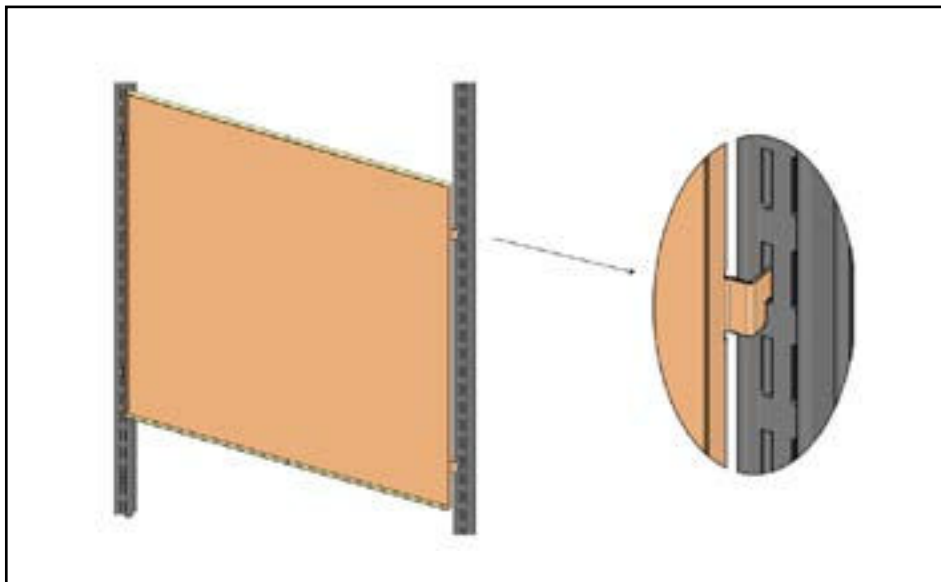

Push down to secure in place.

Accessories

Shelf Tray

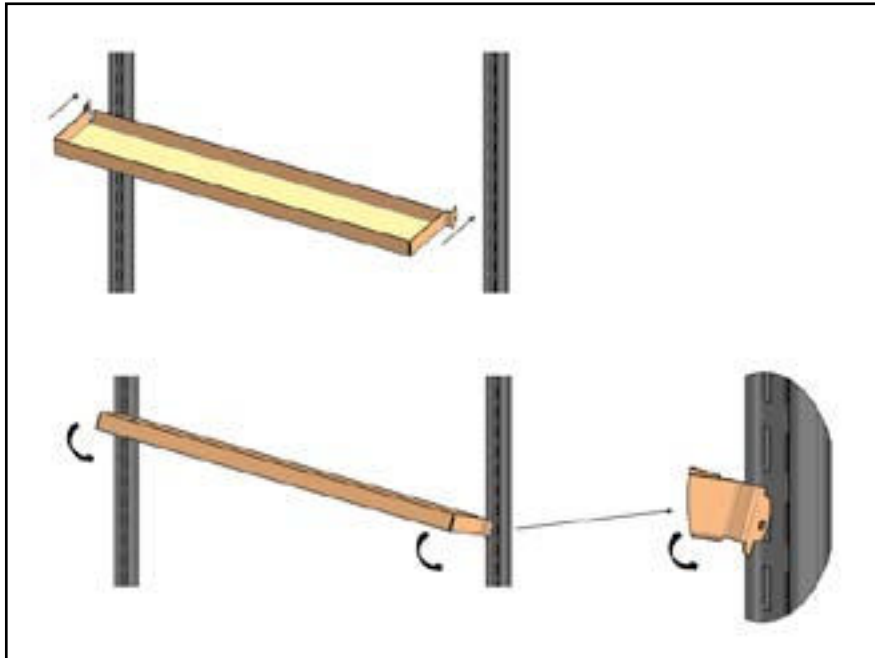

Insert tabs into inner slots at angle shown.

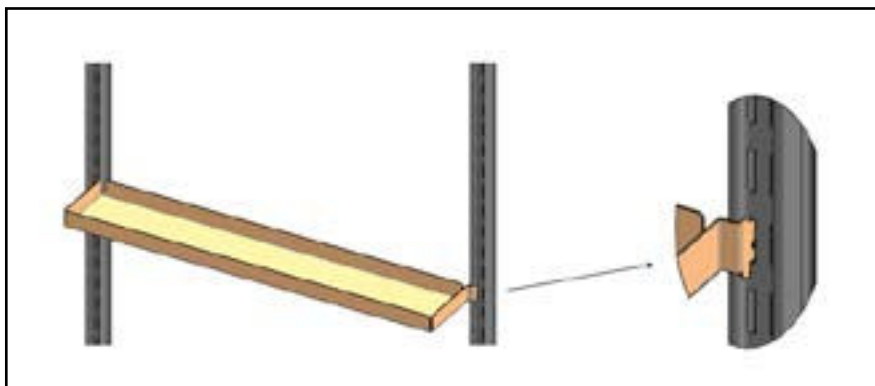

Accessories

Expandable Valet Rod

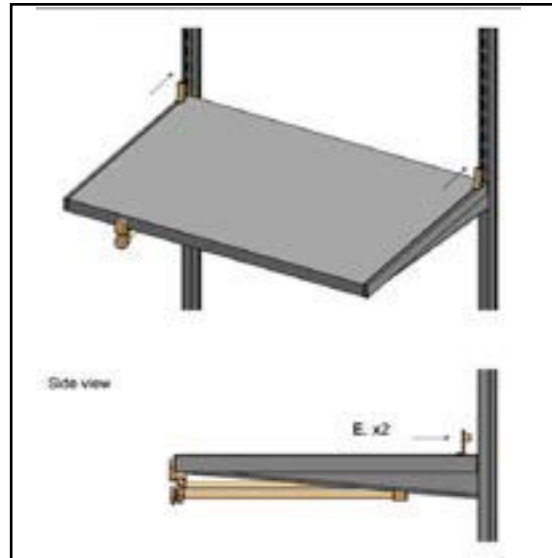
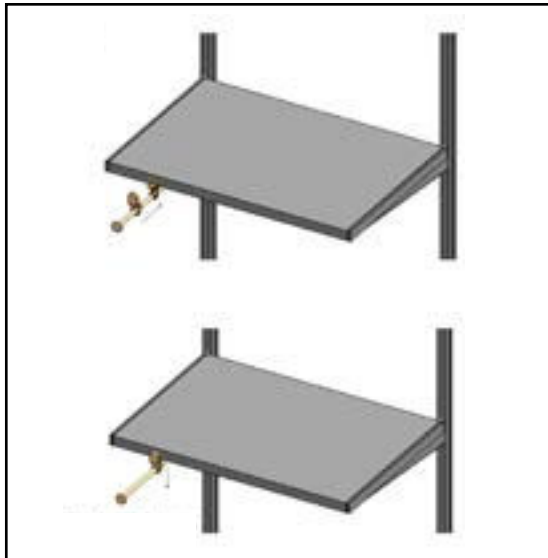
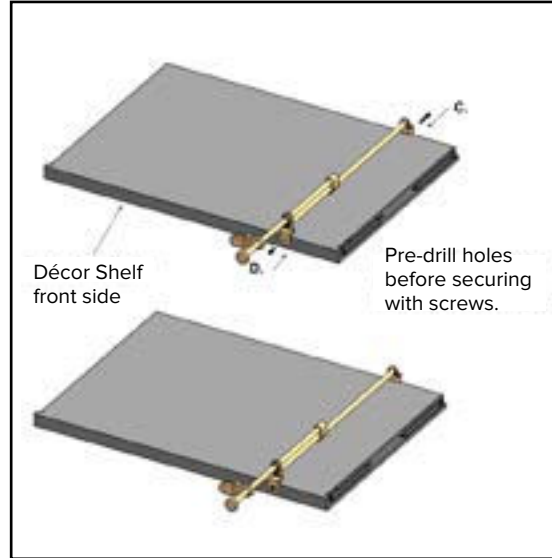
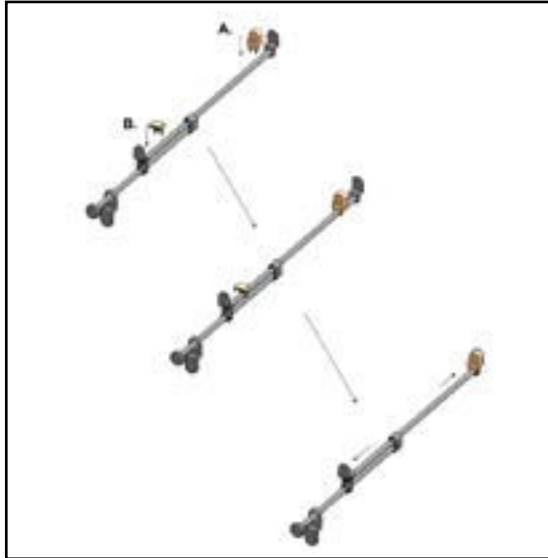
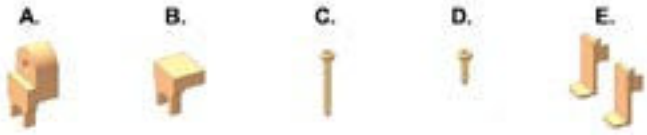

Finishing

Attach Top Track Covers

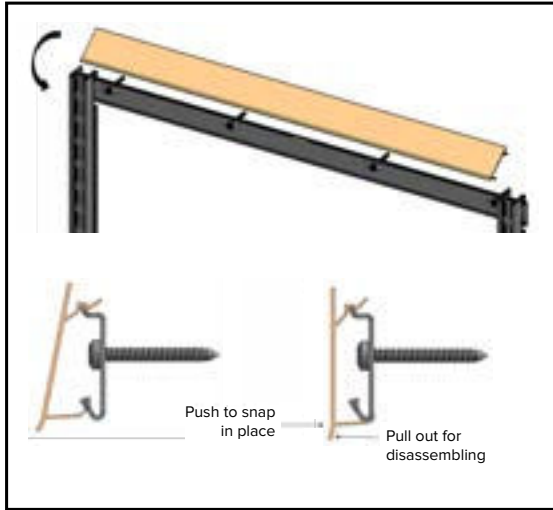

Start with the long pieces first. Cut Top Track Cover to size using a utility knife or scissors. Place top of Top Track Cover on top of the Top Track.

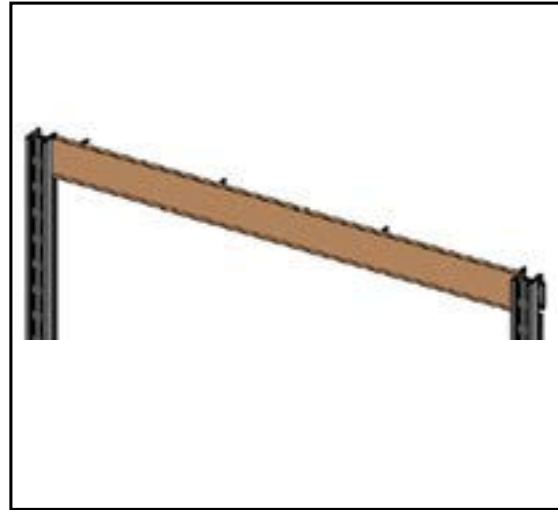

Push the bottom part of the Top Track Cover over the bottom of the Top Track. You may need a bit of force to secure the Top Track Cover.

Attach Standard Covers

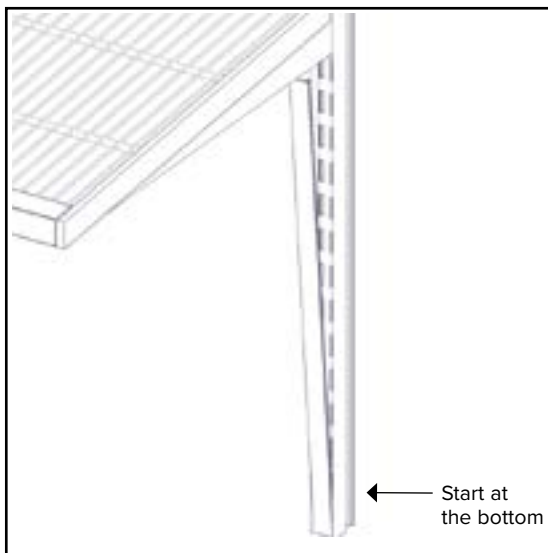

Cut Standard Covers to correct length with utility knife or scissors. Press the top of the Standard Cover in place.

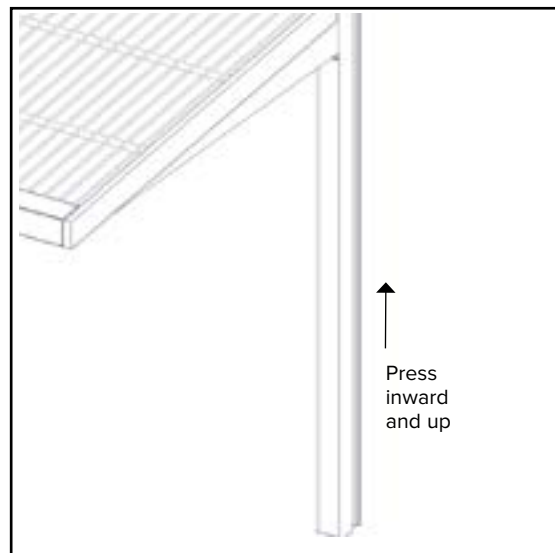

Slide your hand down the Standard, pressing Cover in place.

Finishing

Attach Bracket Covers

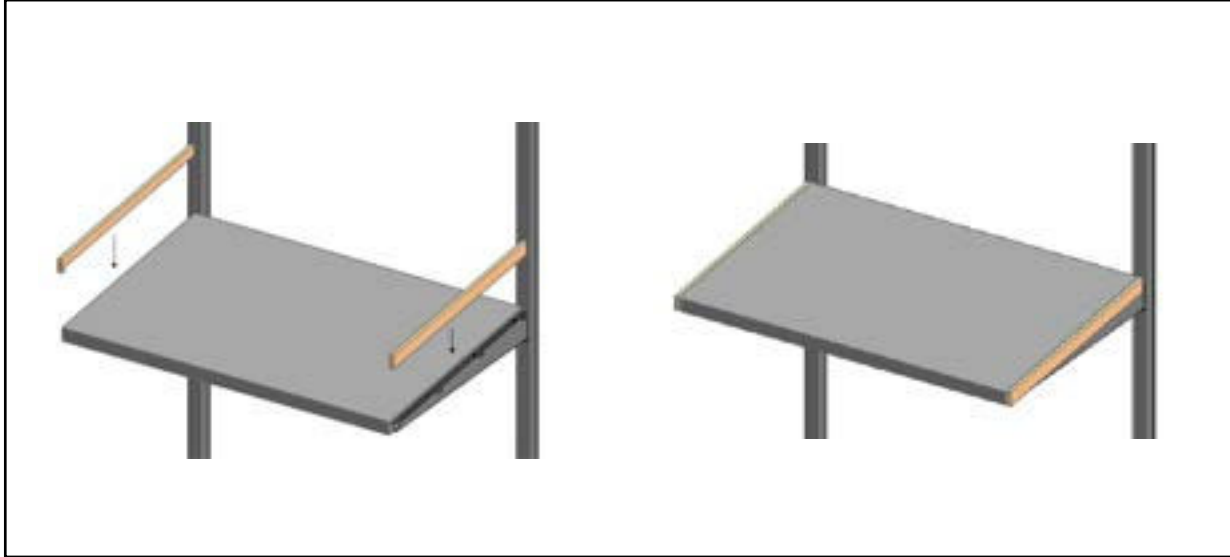

Determine left and right Brackets. Snap Bracket Covers into place over Brackets. Bracket Covers will be in front of Standard Covers.

Attach Shelf Hooks (if applicable)

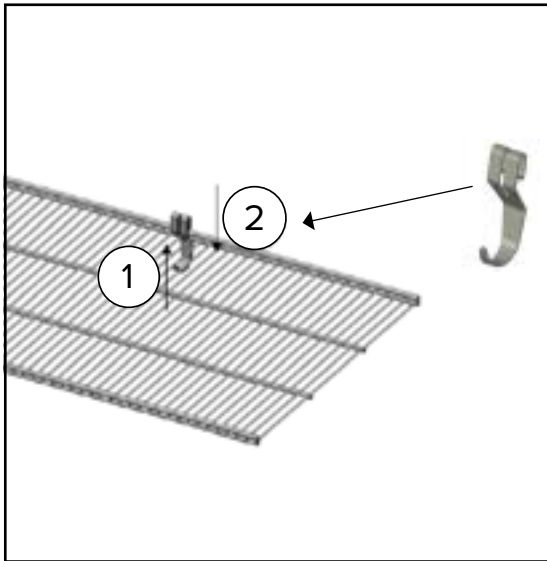

Clip Shelf Hook over edge of Wire Shelf.

Finishing

Attach Trim for Angled Shoe Shelf

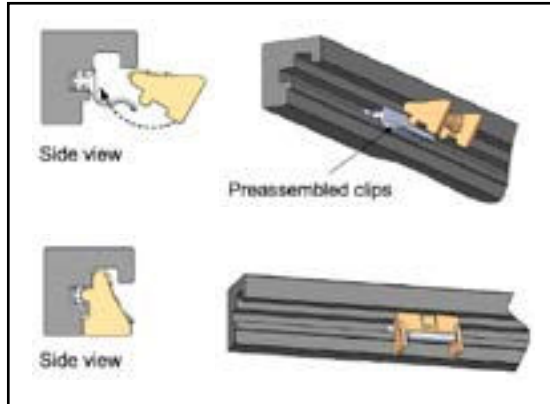

Insert plastic clips into Trim with straight side of the triangle to the back.

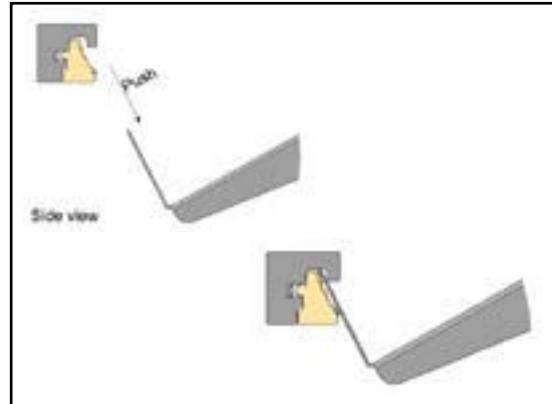

Position Trim in front of the Angled Shoe Shelf. Plastic clip should rest against front face of Angled Shoe Shelf. Push down until it locks in place. Top edge of Angled Shoe Shelf will fit into rounded cutout of Trim as shown.

Attach Trim for Wire Shelf

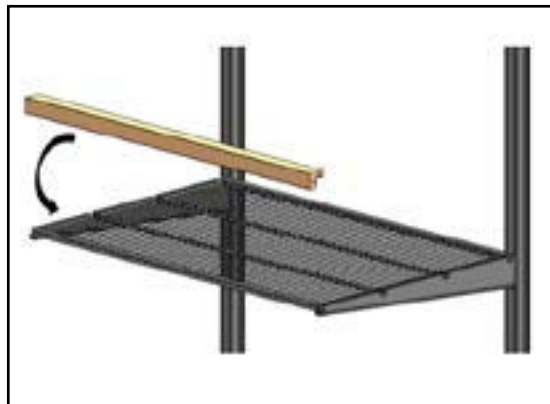

Position Trim with plastic clip in front of Wire Shelf.



Roll into place.